

ARLA[®] Machining Units

High-Precision Units for Modular Production Systems

ARLA[®] Spindle Unit



high-performance unit for facing, tapping, drilling, boring, turning (OD/ID), threading (OD/ID), ...

- high spindle stiffness
- high accuracy concerning concentricity <math>< 2 \mu\text{m}</math>
- models **MA** with an attached direct servo drive
- models **MB, MC** with water cooled spindles
- tool holders: HSK 50-100 (**MA, MB, MC**)
- models **MX** with integrated facing head (see left photo)

ARLA[®] Slide Unit

x- / x-y slide or table directly driven by servo motors, precise linear roller guideways, ball screw drive with rapid traverse (15 ... 60 m/min); standard travel=160 mm (other travels up to 1500 mm on request)

ARLA[®] Machining Unit

CNC machine tool unit consisting of ARLA's spindle and slide unit optionally as integrated unit (**MAL, MBL, MCL**) or as heavy-duty "on-top" unit (**MAS, MBS, MCS, MXS**); CNC control available as an option

Model Overview (here presented together with the concentric ARLA Clamping System, optionally available)

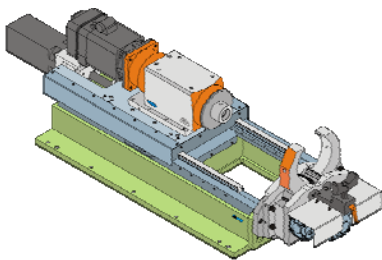

MA

with direct servo drive
+ manual tool clamp

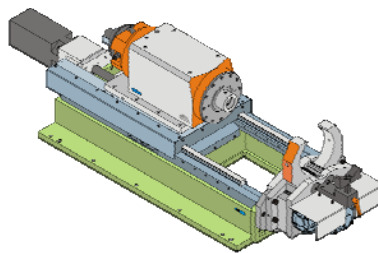

MB

with water cooled motor spindle
+ manual tool clamp

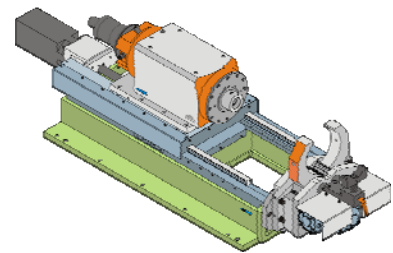

MC

with water cooled motor spindle
+ automatic tool clamp

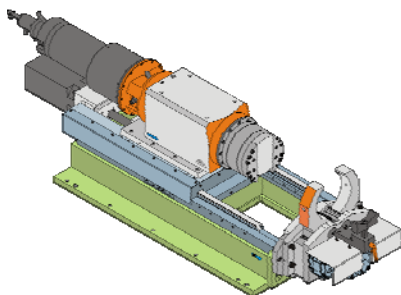

MX

with water cooled motor spindle
(tool configuration suitable for the machining steps)

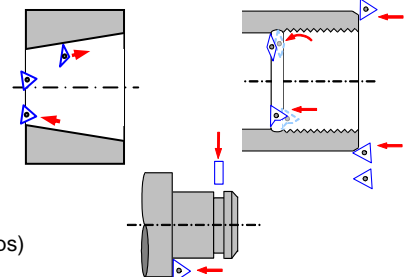

The ARLA[®] Production Idea: Units to be Integrated into Machine Tool Systems & Transfer Lines

ARLA Machining Units are high-precision and stiff units for the manufacturing process. The units are available as a combination of slide or table units and high-performance spindle units for boring, drilling, milling, turning, facing, tapping, threading, deburring, chamfering, etc. for all OD and ID machining steps (even as deep-hole boring units). ARLA Machining Units are part of a total machining center in connection with ARLA's concentric workholding fixtures (ARLA Clamping Systems). The *L Models* (MAL, MBL, MCL) need only a limited space and can be easily integrated (available as HSK 50 and HSK 63). The *S Models* (MAS, MBS, MCS, MXS) are very stiff and can be used as "on-top" units for an integration on a solid machine frame (available for HSK 63, 80, 100).

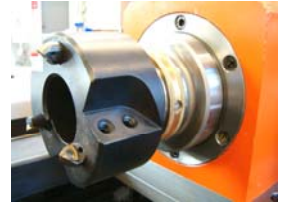

The ARLA Spindle Units are the key components of ARLA's machining concept. These units are very stiff in axial and radial direction and are primarily used for high-performance and accurate machining. According to the application there are various models available dedicated to the optimum machining process – in order to save time & money.

Model Overview and Principal Technical Data of ARLA[®] Machining Units

MA	MAL 050-015	MAL 050-020	MAL 063-055 MAS 063-055	MAL 063-080 MAS 063-080	MAS 080-080	MAS 080-100	MAS 100-160
	HSK A	50		63		80	100
T _{max} [Nm]	17	22	56	80	80	98	160
n _s [1/min]	6000	6000	2000	2000	2000	2000	1500
P _s [kW]	10,7	13,8	11,7	16,8	16,8	20,5	25,1

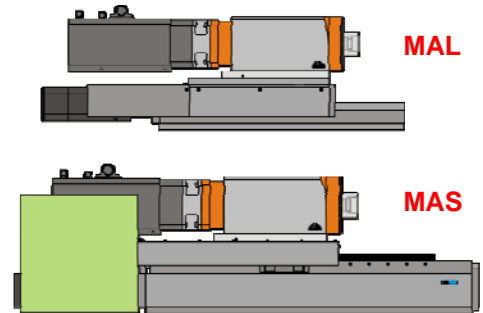

MB MC	MBL / MCL 050-030	MBL / MCL 050-040	MBL / MCL 063-070 MBS / MCS 063-070	MBL / MCL 063-120 MBS / MCS 063-120	MBS / MCS 080-175	MBS / MCS 080-245	MBS / MCS 100-375	MBS / MCS 100-425
	HSK A	50		63		80	100	100
T _{max} [Nm]	27,5	40,5	70	120	175	245	375	425
n _s [1/min]	7000	7000	4000	2000	1700	1200	700	600
P _s [kW]	20,2	29,7	29,3	25,1	31,2	30,8	27,5	26,7

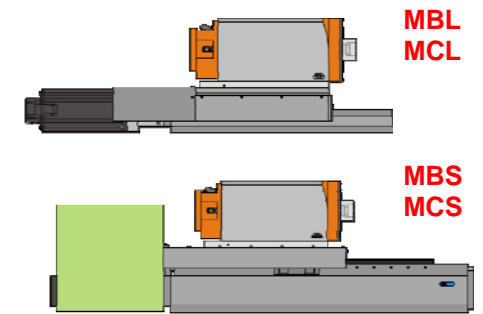

MX	MXS 100-070	MXS 100-090	MXS 125-090	MXS 125-120	MXS 160-120	MXS 160-140	MXS 200-140	MXS 200-175	MXS 250-175	MXS 250-245	MXS 320-425
	Facing Head	100		125		160		200		250	
T _{max} [Nm]	70	90	90	120	120	140	140	175	175	245	425
n _s [1/min]	4000	3100	3100	2000	2000	2100	2100	1700	1700	1200	600
P _s [kW]	29,3	29,2	29,2	25,1	25,1	30,8	30,8	31,2	31,2	30,8	26,7

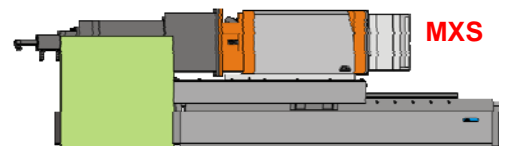

Ask for detailed data sheets.
Subject to modifications.

© 2002-2009. ARLA Maschinentechnik GmbH.
All rights reserved. Update: 02.2009